



THE **WASP**
ELECTRIC PARK FLYER



ASSEMBLY INSTRUCTIONS
Version 1.0

Kit Contents:

- 1 - Plan sheet
- 1 - Instruction Manual
- 1 - 1/4" Laser Cut Balsa Fuselage
- 1 - 1/8" Laser Cut Lite-Ply Fuselage Bottom
- 1 - 1/8" Laser Cut Lite-Ply Wing Brace
- 1 - 1/16" Laser Cut Plywood Fitting Set
- 2 - 1/8" Laser Cut Balsa Parts Sheet
- 1 - 1/16" Laser Cut Balsa Parts Sheet
- 1 - Hardwood Dowel
- 1 - 1/16" x 24" Piano Wire
- 1 - 1/32" x 24" Piano Wire

Suggested Radio Gear:

- 3 Channel Transmitter
- 2 - Sub Micro Servos
- 1 - Micro Receiver
- 1 - Micro ESC, 2~5 Amp.

Other Items Required to Complete the Kit:

- Motor: IPS-DX-AXC
- Propeller: 9 x 7
- Batteries: 7~8 Cell, 350+mah Nicad or NiMH
- 2 - Dubro 150MW 1-1/2" Micro Lite Wheels
- 1 - Roll of Solar Film – Solar Film So-lite
- Double Sided Tape

Items Required for Building:

- Thin Cyanoacrylate adhesive
- White glue
- Straight Pins
- Building Board
- Wax Paper
- Razor Blade or X-Acto Knife
- Fine Grit Sand Paper

Before Beginning:

IMPORTANT: Before you begin construction please read instructions and plan sheet. Always test fit before gluing. Place plan sheet on building board and cover with wax paper to prevent parts from sticking to them.

Tail Surfaces:

- Build tail surfaces over plan. Remove only those parts needed for each individual assembly at a time. Check parts for fit before gluing. Do not glue in the elevator control horn until after covering.

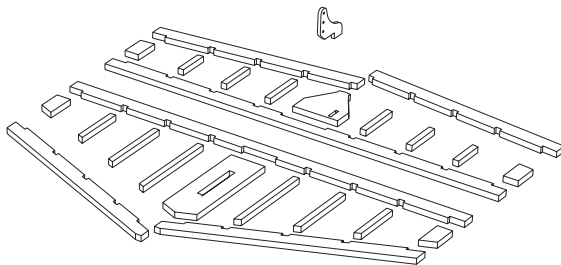

Elevator Parts, 1/8 Balsa



Horizontal Stab Parts, 1/8 Balsa



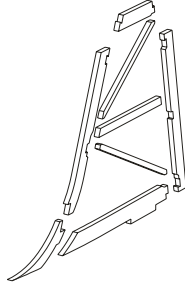

Vertical Stab Parts, 1/8 Balsa

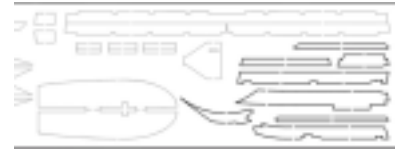

Fuselage:

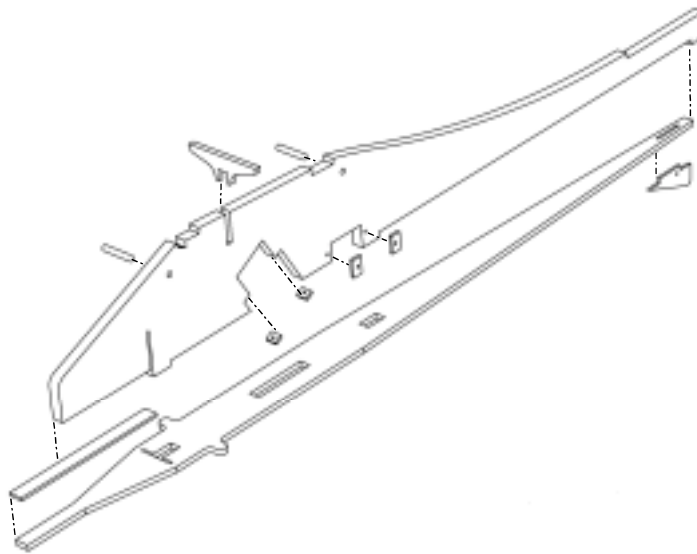

Fuselage Parts, 1/16 Ply

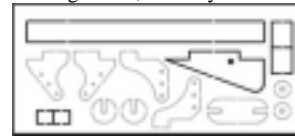

- Start by gluing the *Motor Mount* to the *Fuselage Bottom Plate*. Use slow setting glue such as white glue so that you have time to adjust it into its proper position. Check it's alignment by test fitting the motor gearbox. Let dry.
- Glue the main *Fuselage* piece to the *Bottom Plate* making sure that they are perpendicular and that they line-up near the tail. Let dry.
- Add plywood *Servo Mounts*, *Tail Skid* and two $\frac{3}{4}$ " long *Wing Attachment Dowels*.
- DO NOT GLUE** the *Wing Support Bracket* at this time. For it to be most effective it should be tight against the bottom of the wing when the wing is in position. When the wing is assembled slide the bracket into position and then mount the wing. Slide the bracket, if necessary, up to make contact with the wing and then bond in place.

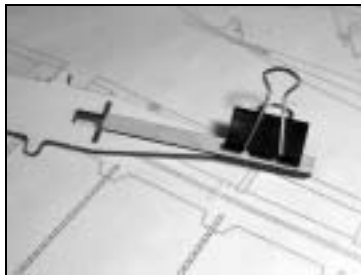

Landing Gear (Optional):

- Insert *Landing Gear Wire* into the slot in the *Fuselage Bottom Plate*. Push it all the way to the top of the vertical slot in the Fuselage. Glue the two *Circular Retainers*, one on either side of the *Fuselage*, capturing the wire. Align the retainers so that the slot is pointing towards the back.

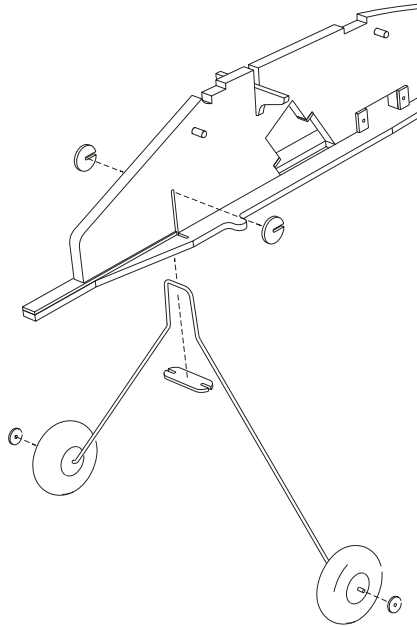

Landing Gear Mounting Parts, 1/16 Ply

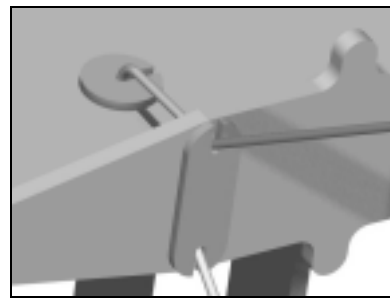
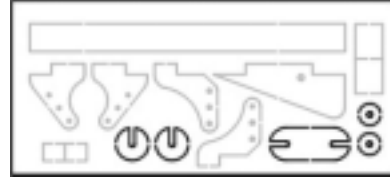

- Glue the *Bottom Landing Gear Retainer* to the underside of the *Fuselage Bottom Plate* so that the L.G. wire is in each of the two slots. If you choose not to install the landing gear the *Bottom Landing Gear Retainer* should still be glued to the *Fuselage Bottom Plate*.

Wing:

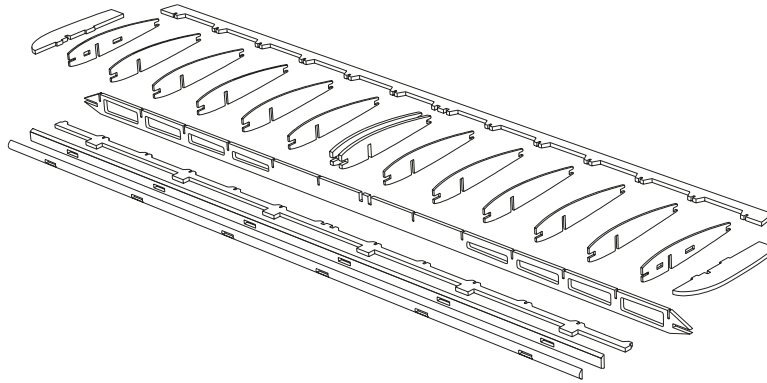

- Start by gluing together the *Main Spar*, *Trailing Edge* and *Leading edge Rail*. Check over plan that the rib slots in the spar line-up with the Ribs on the plan sheet. Check to make sure that the parts are straight when glued.

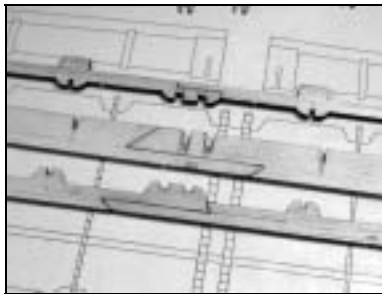

- Place all the *Ribs* into the Rib slots on the *Main Spar*. Do not glue at this time. The 1/8" thick *Ribs* go in the center of the wing and two *Ribs* with rectangular holes will go at the *Wing Tips*. Insert the *Trailing Edge* and *Leading Edge Rail* into the slots in the *Ribs*.

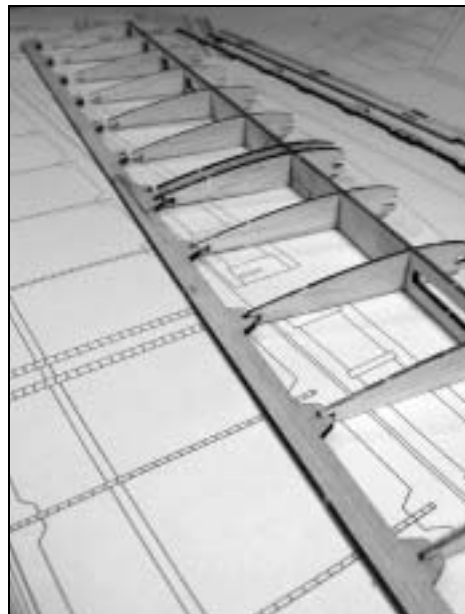

- Pin in place over the plan making sure everything is square. The *Trailing Edge* should be supported with 1/8" thick pieces of balsa. Glue the *Ribs* to the *Spar* and *Rails* with thin Cyanoacrylate. Remove the wing from the board and glue all joints from the bottom.



- Glue the *back leading edge* piece, the wider of the two, to the *leading edge rail* and the front of the *ribs*, sliding in onto the rectangular tabs on the front of the *leading edge rail*. The marked arrows on the front face of the *back leading edge* should point to the top of the wing.

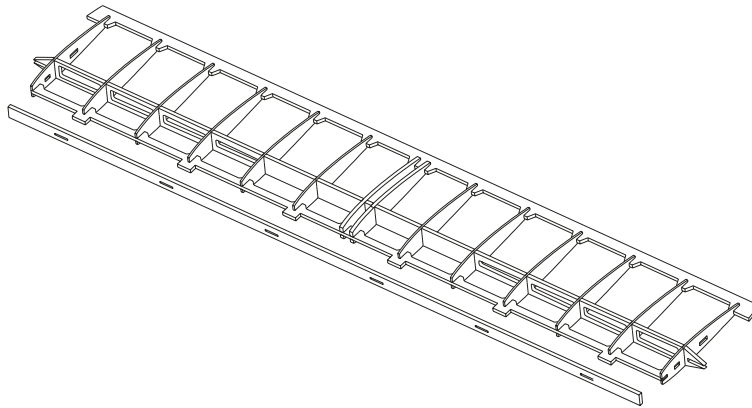

- Now glue the *leading edge front* piece, to the *back leading edge* piece, again making sure that the arrow markings are pointed to the top of the wing. Glue the face with the arrows to the *back leading edge*, doing this flips the joint in the middle of these two pieces so that when they are bonded together they do not line up.

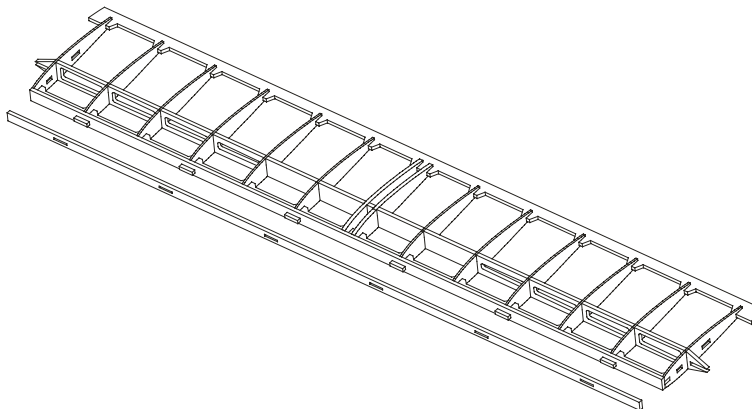

- Glue on the wing tips

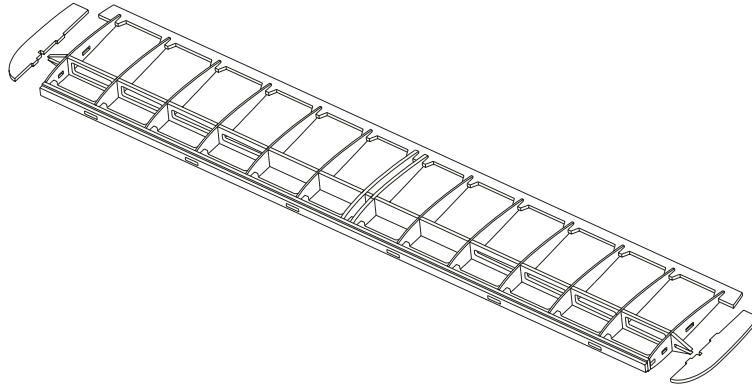

Ailerons:

- Build *ailerons* over the plan. Remove only those parts needed for each individual *aileron* at a time. Check parts for fit before gluing. Don't glue in the *aileron control horns* until after covering.

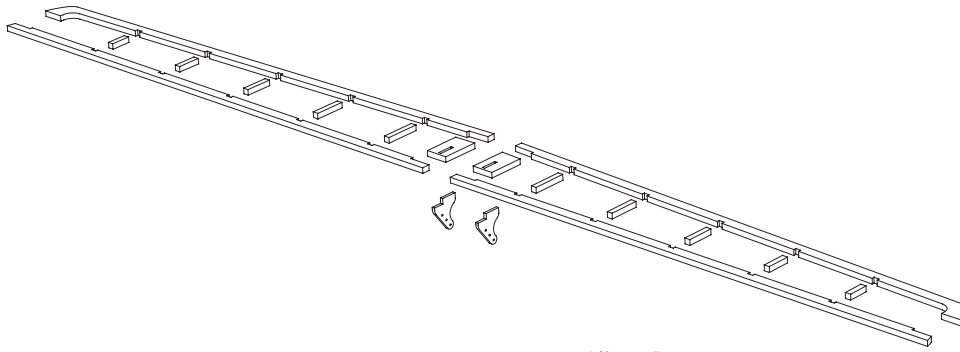

Aileron Parts



Final Assembly:

- Hinges:**

Plastic covering material hinges: Bevel the leading edges of the ailerons and elevator 30 degrees from the top front leading edge to the bottom edge.

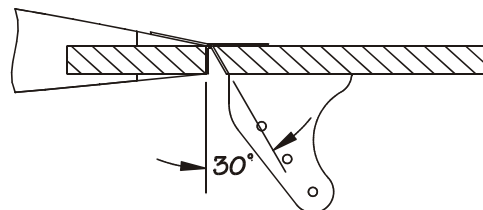

CA hinges: Cut hinge slots in the trailing edge of the wing and the leading edge of the aileron at the specified locations.

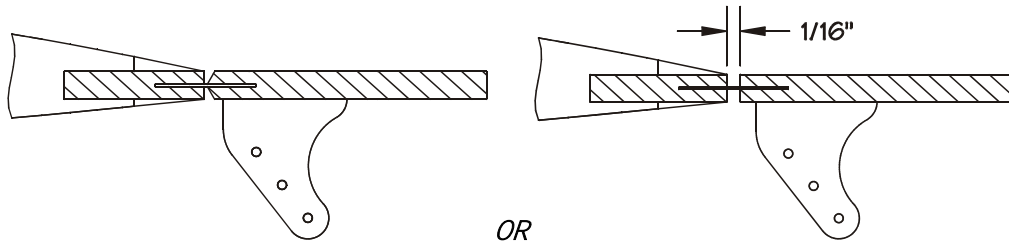

AILERON SET-UP

When installing the aileron control linkages, set-up the ailerons with 4 degrees of down trim and around +/-20 degrees of control travel. The range of control movement can be altered to adjust the sensitivity of the aileron control.

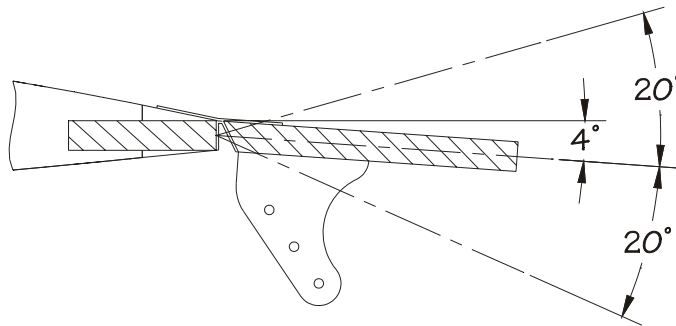

- Cover the *Wing, Horizontal Stabilizer, Elevator* and *Vertical Stabilizer* with preferred covering material. Do not cover the bottom and tab of the *Vertical Stabilizer*, the area on top of the *Horizontal Stabilizer* under the *Vertical Stabilizer* on and the area under the *Horizontal Stabilizer* covered by the *Fuselage*. Remove the covering from the bottom of the *Wing* between the 2 middle *Ribs*. Make sure the covering is adhered well to the frame in this area.
- Install *Control Horns*. Remove plastic covering to allow gluing of the *Control Horns*.
- Glue *Vertical Stabilizer* to the *Horizontal Stabilizer*. Make sure the *Vertical Stab* is perpendicular.
- Glue the *Horizontal Stab* and front portion of the *Vertical Stab* to the *Fuselage*.
- Install *Hinges*.
- Seal and paint the fuselage. Avoid painting areas covered by the *Motor* and *Wing*.

- Install *Servos*.
- Bend and install *Elevator pushrod*. An extra *Elevator control horn* is included for bracing the pushrod at its midpoint. Install by sliding the control horn onto the pushrod then insert the correct end of the pushrod into the elevator control horn. Insert other end into the elevator servo's control horn while it is removed from the servo. Attach servo control horn to the servo. Position and glue control horn brace.

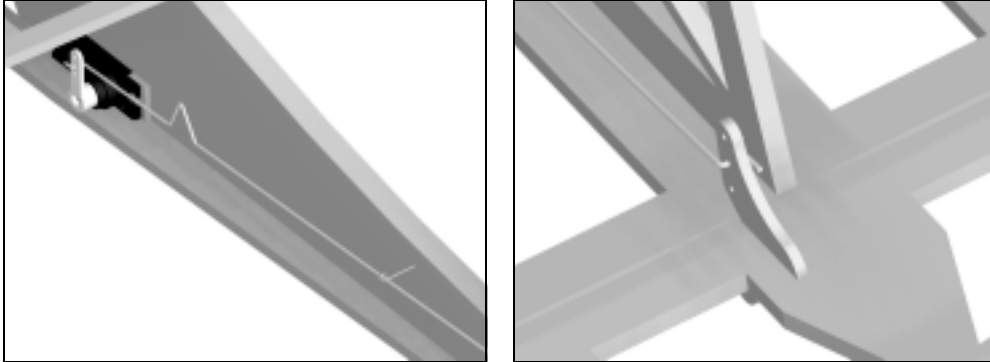

- Bend and install *aileron pushrods*. Attach the aileron pushrods to the aileron control horns first. As the Wing is being mounted to the fuselage insert the other end of each pushrod into the aileron servo's control horn. Secure wing with elastic bands. Adjust neutral position of the ailerons by expanding or squeezing the "V" shaped bend.

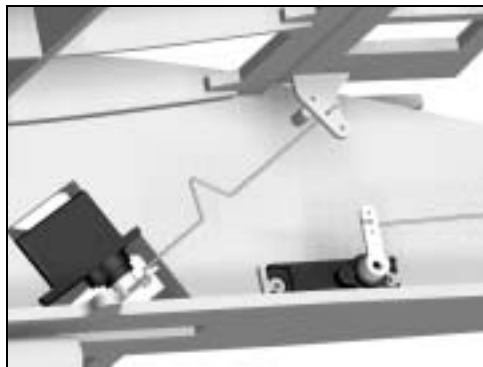

- Install *Wheels*. Plywood washers have been provided for securing the wheels onto the landing gear wire. Slide them onto the wire after the wheels and glue in place.
- Install *Motor*.
- Install *Receiver and ESC*. Use double sided tape to mount to the *Fuselage*.
- Install *Batteries*. Position the batteries so that the model balances at the main wing spar.
- Fly!